

**Inductive (half-bridge) probe sensor:**



- WT series in Ø12 mm standard case,
- WTA series with Ø8 mm clamping shank,
- for industrial applications in production and test.

**Specifications**

		WT / WTA 2	WT / WTA 5	WT / WTA 10	WT / WTA 20	WT / WTA 50	WT / WTA 100
Nominal stroke	mm	±1	±2,5	±5	±10	±25	±50
Mechanical stroke	mm	±1,6	±3,5	±6	±11	±26	±52
Dimension A	mm	8	12	15	20	35	65
Dimension B	mm	80	87	140	172	250	410
Spring force at centre position (appr.)	N	0,7	0,8	1,1	1,5	2,7	2,7
Spring constant (approx.)	N/mm	0,045	0,056	0,040	0,067	0,085	0,050
Sensor weight (approx.)	g	40	50	80	90	130	200
Core weight (approx.)**)	g	5	6	12	15	18	28
Nominal output (approx.)	mV/V	48	120	100	150	225	300
Sensitivity (approx.)	mV/V/mm	48	48	20	15	9	6
Excitation voltage (rms)	V <sub>rms</sub>	Up to 5					
Carrier frequency	kHz	5 ... 10					
Linearity *)		0,5% FSO , option 0,25% and 0,1%					
Temperature coefficient of zero		±0,05% / 10K			±0,02% / 10K		
Temperature coefficient of span		±0,1% / 10K			±0,05% / 10K		
Stroke marks on core rod (option *)		Option: zero mark (all models) and stroke ends (10 mm up)					
Operating temperature *)		-50°C ... +80°C Option: up to 120°C					
Protection		IP 54					

\*) Specify options on order

\*\*) Probe tip with M2,5 standard thread; probe tip can be released/exchanged by slightly warming up thread locker

**Model list**

Order code:

WT WTA nnn NN n,n % /Option1 /Option2 ...

Series		Stroke	Connection					Linearity (FSO)			Options						
WT	WTA (8 mm shank)	2 ... 100	Leads	Axial cable	Axial connector	Radial connector	Radial connector	0,5%	0,25%	0,1%	High operating temperature <sup>1)</sup>	Stroke marks on core rod (see picture)	PTFE cable <sup>3)</sup>	Reduced spring force	Bellow <sup>4)</sup> (see picture)	Customised Dim. A	Probe tip not glued
			o	K	LX	LR	Q				/120°C	/M	/TF	/GF	/FB	/A xx	/NV
X	X	2	X	X	X	X	X	X	X	--	O	O <sup>2)</sup>	O	O	O	O	O
X	X	5	X	X	X	X	X	X	X	X	O	O <sup>2)</sup>	O	O	O	O	O
X	X	10	--	X	X	X	X	X	X	X	O	O	O	O	O	O	O
X	X	20 ... 100	--	X	X	X	X	X	X	X	O	O	O	O	--	O	O

X = available standard model

O = option -- = not available

1) PTFE cable with versions K and Q

2) zero mark only

3) with versions K and Q only

4) not with option /M and not with /120°C

## Mechanical drawings

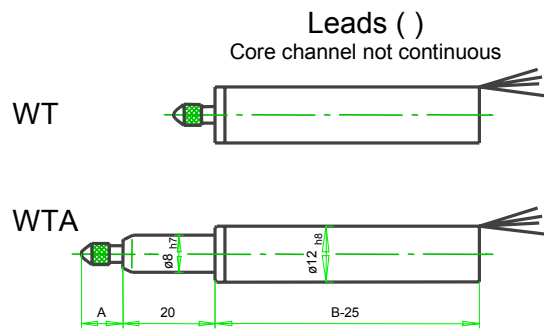
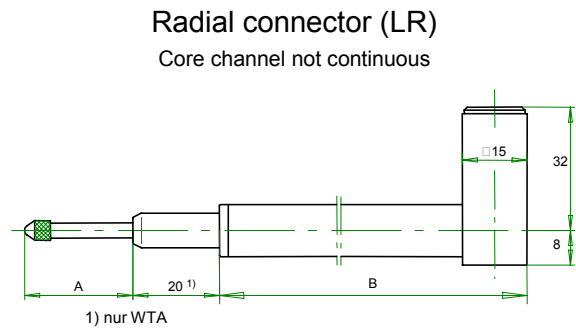
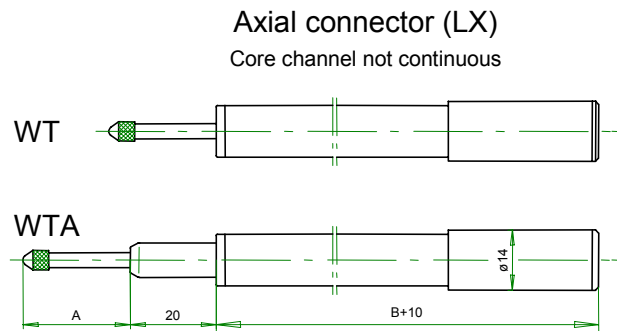
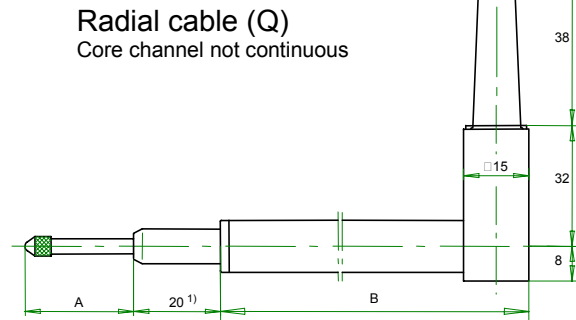
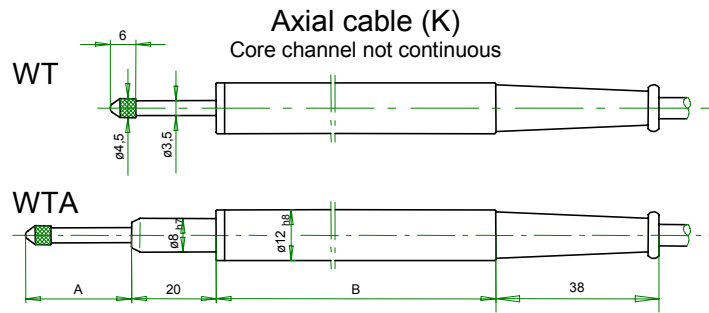

## Connection

	Leads	K / Q	LR / LX
Type of connection	PTFE leads 250 mm long	PE-cable 2,5 m long Option: PTFE cable	LEMO ERA.1S.303.CLL (Mating plug supplied)
Pin configuration	red yellowwhite blue 	red white blue 	
Power supply +	Blue	Blue	3
Power supply -	Red	Red	2
Measuring signal +	White+Yellow	White	1
Measuring signal -	-	-	-
Mating plug	-	-	LEMO FFA.1S.303CLAC52

## Options

### Option /M

Stroke marks on core rod



### Option /FB

Bellow on core rod (up to 10 mm)

increased dim. A

