

Long-stroke Displacement Transducer

Integrated electronics

Supply +20...30 VDC

Output 4...20 mA

Pressure resistant up to 320 bar

WI
2-wire-interface

MESSOTRON

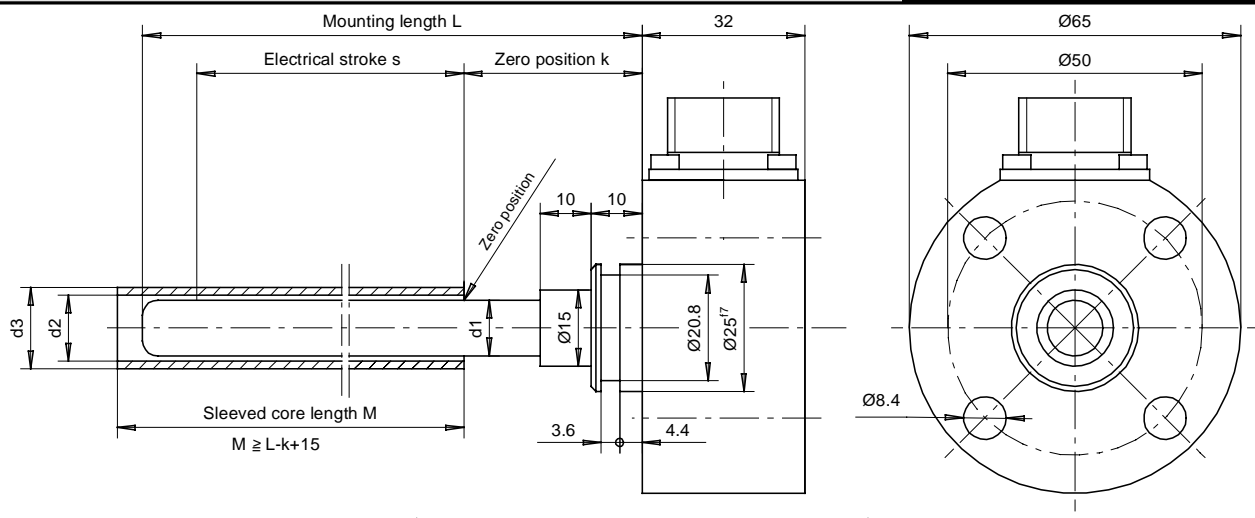

radial wire interface
Teflon cable 2.5 m long

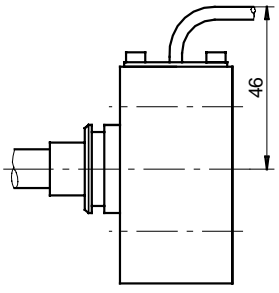

Example: WI 300 Q

radial connector interface
mating connector supplied

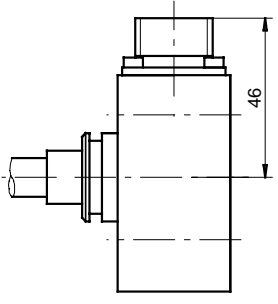

Example: WI 300 R

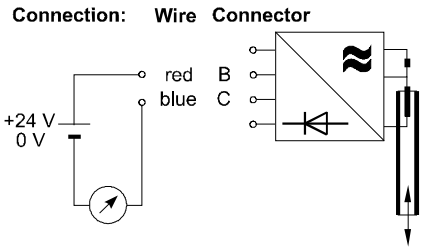

		WI 60	WI 120	WI 160	WI 200	WI 300	WI 400	WI 500	WI 600	WI 800	WI 1000
Electrical stroke	mm	60	120	160	200	300	400	500	600	800	1000
Maximum mechanical stroke	mm	70	130	180	230	330	430	530	650	880	1100
Mounting length L	mm	120	190	235	310	410	510	610	750	1000	1250
Zero position k	mm	35	35	35	45	45	60	60	60	80	80
Transducer diameter d1	mm	11	11	11	11	11	12	12	12	12	12
Sleeved core diameter d3/d2	mm	16/13	16/13	16/13	16/13	16/13	18/14	18/14	18/14	18/14	18/14
Sleeved core length M	mm	120	190	235	310	410	510	610	750	1000	1250
Transducer weight	g	700	730	750	800	900	1000	1100	1200	1300	1500
Sleeved core weight	g	30	40	50	60	80	150	190	230	280	350
Supply	20 ... 30 V / 40 mA, stabilized										
Output signal	4 ... 20 mA										
Allowable load	max. 400 Ohm										
Static resolution	virtually infinite										
Cut-off frequency	100 Hz										
Linearity	±0.5% F.S.O.										
Temperature coefficient of zero	±0.25% / 10K										
Temperature coefficient of span	±0.25% / 10K										
Pressure resistance	operating pressure 320 bar, test pressure 500 bar										
Operational temperature	0°C ... +60°C										
Protection class (DIN 40050)	IP 65										

MESSOTRON
Hennig GmbH & Co. KG
Industrie-Messtechnik
Friedr.-Ebert-Str. 37, Tel.: (06257)82331
D-64342 Seeheim-Jugenheim

WI Series
60 ... 1000 mm

Drawing
17.40.00

Date 08/99

Design of transducers can be customised

Subject to change without prior notice