

Long-stroke Displacement Transducer

Integrated electronics

Supply ± 15 VDC

Output 4...20 mA

Pressure resistant up to 320 bar

WA

MESSOTRON

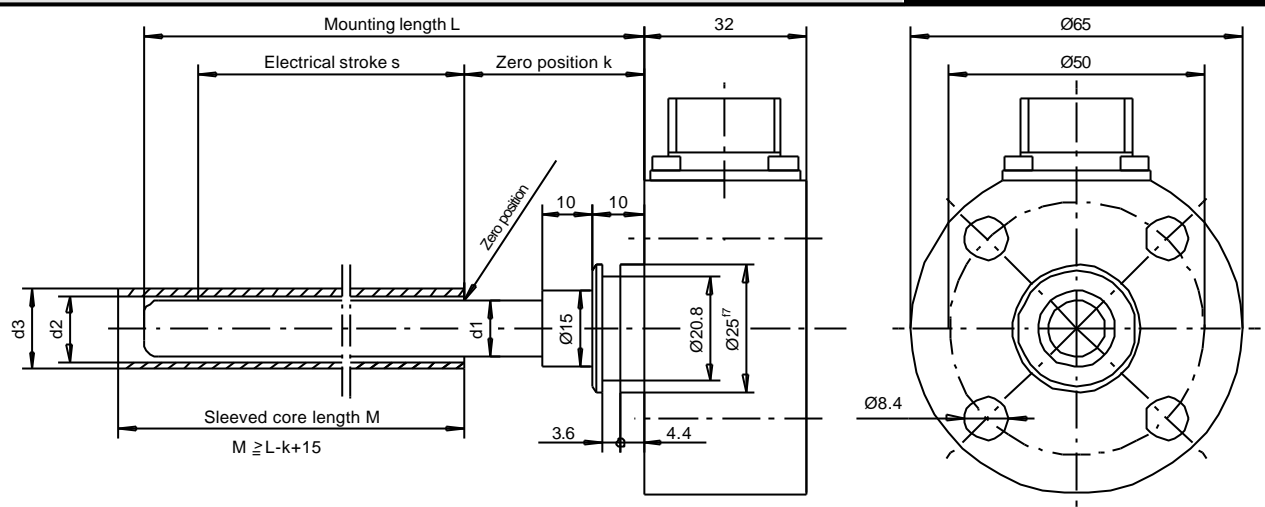

radial wire interface

Teflon® cable 2.5 m long

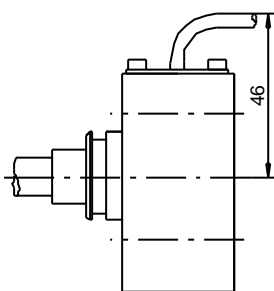

Example: WA 300 Q

radial connector interface

mating connector supplied

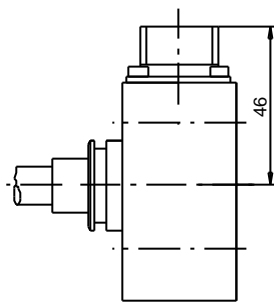

Example: WA 300 R

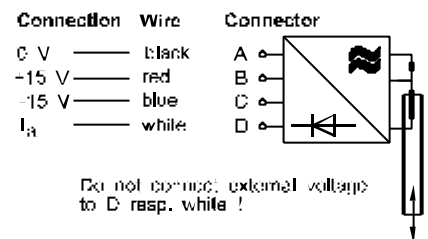

		WA 60	WA 120	WA 160	WA 200	WA 300	WA 400	WA 500	WA 600	WA 800	WA 1000
Electrical stroke	mm	60	120	160	200	300	400	500	600	800	1000
Maximum mechanical stroke	mm	70	130	180	230	330	430	530	650	880	1100
Mounting length L	mm	120	190	235	310	410	510	610	750	1000	1250
Zero position k	mm	35	35	35	45	45	60	60	60	80	80
Transducer diameter d1	mm	11	11	11	11	11	12	12	12	12	12
Sleeved core diameter d3/d2	mm	16/13	16/13	16/13	16/13	16/13	18/14	18/14	18/14	18/14	18/14
Sleeved core length M	mm	120	190	235	310	410	510	610	750	1000	1250
Transducer weight	g	700	730	750	800	900	1000	1100	1200	1300	1500
Sleeved core weight	g	30	40	50	60	80	150	190	230	280	350
Supply		± 15 V / 40 mA, stabilized									
Output signal		4 ... 20 mA; option 0 ... 20 mA									
Allowable load		max. 400 Ohm									
Static resolution		virtually infinite									
Cut-off frequency		100 Hz									
Linearity		$\pm 0.5\%$ F.S.O.									
Temperature coefficient of zero		$\pm 0.3\%$ / 10K									
Temperature coefficient of span		$\pm 0.3\%$ / 10K									
Pressure resistance		operating pressure 320 bar, test pressure 500 bar									
Operational temperature		0°C ... +60°C									
Protection class (DIN 40050)		IP 65									

MESSOTRON
 Hennig GmbH & Co. KG
 Industrie-Messtechnik
 Friedr.-Evert-Str. 37, Tel.: (06257) 82331
 D-64342 Seeheim-Jugenheim

WA Series
 60 ... 1000 mm

Drawing
 17.30.12

Date 01/00

Design of transducers can be customised

Subject to change without prior notice